

1-1-2015

Short-term load forecasting without meteorological data using AI-based structures

İDİL İŞIKLI ESENER

TOLGA YÜKSEL

MEHMET KURBAN

Follow this and additional works at: <https://journals.tubitak.gov.tr/elektrik>



Part of the [Computer Engineering Commons](#), [Computer Sciences Commons](#), and the [Electrical and Computer Engineering Commons](#)

Recommended Citation

ESENER, İDİL İŞIKLI; YÜKSEL, TOLGA; and KURBAN, MEHMET (2015) "Short-term load forecasting without meteorological data using AI-based structures," *Turkish Journal of Electrical Engineering and Computer Sciences*: Vol. 23: No. 2, Article 4. <https://doi.org/10.3906/elk-1209-28>
Available at: <https://journals.tubitak.gov.tr/elektrik/vol23/iss2/4>

This Article is brought to you for free and open access by TÜBİTAK Academic Journals. It has been accepted for inclusion in Turkish Journal of Electrical Engineering and Computer Sciences by an authorized editor of TÜBİTAK Academic Journals. For more information, please contact academic.publications@tubitak.gov.tr.

Short-term load forecasting without meteorological data using AI-based structures

İdil İŞIKLI ESENER, Tolga YÜKSEL*, Mehmet KURBAN

Department of Electrical and Electronics Engineering, Bilecik Seyh Edebali University, Bilecik, Turkey

Received: 06.09.2012 • Accepted: 05.03.2013 • Published Online: 23.02.2015 • Printed: 20.03.2015

Abstract: STLF is used in making decisions about economical power generation capacity, fuel purchasing, safety assessment, and power system planning in order to have economical power conditions. In this study, Turkey's 24-hour-ahead load forecasting without meteorological data is studied. ANN, wavelet transform and ANN, wavelet transform and RBF NN, and EMD and RBF NN structures are used in STLF procedures. Local holidays' historical load data are changed into data with normal day characteristics, and the estimation results of these days are not included in error computation. To obtain more accurate results, a regulation on forecasted loads is proposed. Regulated and unregulated forecasting error percentages are computed as daily average MAPE and maximum daily MAPE, and compared between the proposed structures. A simulation is performed for the years 2009–2010 via the user interface created using MATLAB GUI.

Key words: Short-term load forecasting, artificial neural networks, radial basis function neural networks, wavelet transform, empirical mode decomposition

1. Introduction

Electric power distribution is based on providing continuous, reliable, and economical power to consumers. Despite increasing load demand, these principles should not be compromised. Hence, electric power system planning becomes the most important point to focus on in the scope of energy. As the first step of system planning, load forecasting should be effective, since it determines the entire planning process. Power system planning based on load forecasting that is lower than required leads to restriction of energy to consumers, while planning based on the estimation of excess load results in uneconomical operating conditions [1].

Load forecasting is classified as short-term, mid-term, and long-term load forecasting based on forecasting time range. Short-term load forecasting (STLF) is defined as hourly through daily forecasting, mid-term load forecasting is estimation from 1 hour to 1 year, and long-term load forecasting extends from 1 year to more [2]. STLF is used in making decisions for economical power generation capacity, fuel purchasing, safety assessment, and power system planning in order to have economical power conditions.

The methods developed for load forecasting are generally analyzed in 2 categories, analytical methods and artificial intelligence methods. Commonly used analytical methods in the literature are time series analysis, regression methods, similar day method, least square estimation (LES), and wavelet transform (WT). Analytical methods work well in normal daily conditions, but they cannot give satisfactory results when subject to meteorological, sociological, or economic changes, or the change in load demand during holidays, since they are

*Correspondence: tolga.yuksel@bilecik.edu.tr

not updated over time. For this reason, artificial intelligence (AI) methods have gained importance in reducing estimation errors. Artificial neural networks (ANN), fuzzy logic (FL), support vector machines (SVM), genetic algorithms (GA), particle swarm optimization (PSO), and ant colony optimization (ACO) based methods are among these AI methods. In addition to these, hybrid methods consist of more than 1 artificial intelligence method or analytical method, or 2 together. Furthermore, WT is used as a preprocessing tool for AI-based forecasting.

Factors that affect load demand must be determined well and considered in forecasting studies in order to produce effective forecasting. These factors can be defined as consumption region and independent variables like day of the week, sociological, meteorological, demographic, and economic conditions. Demographic and economic conditions are generally used in long-term load forecasting studies [3], and temperature data are mostly used as an independent variable in STLF studies [1,2,4–14]. In addition to temperature data, other meteorological variables like wind, humidity, and precipitation are used in studies [2,7,9,11,15]. There are also studies using only historical load data [8,16–20]. STLF studies in the literature mostly focus on regional load forecasting [1,2,5,6,8,9,11,13,14,17].

In this study, Turkey's 24-hour-ahead load forecasting for the years 2009–2010 was achieved using Turkey's historical load data from 1 December 2008 to 31 December 2010, obtained from TEIAS. By contrast with regional load forecasting, it is quite difficult to obtain and use an effective temperature dataset for large-scale studies like countrywide estimations with populations of more than 1 million. Therefore, in this study, load forecasting without temperature data is attempted for a large country. Four different structures are used in the STLF procedure: ANN, WT and ANN, WT and RBF NN, empirical mode decomposition (EMD) and RBF NN. Forecasting error percentages are computed as mean absolute percentage error (MAPE) and compared among these 4 structures. Simulation is performed via the user interface artificial intelligence for short-term load forecasting (AI-STLF) created using MATLAB GUI.

This paper is organized as follows. In Section 2, studies in the literature related to short-term forecasting are summarized. In Section 3, WT, RBF NN, and EMD are explained briefly. Input data selection and formulations for the study are given in Section 4. In Section 5, the STLF procedure is explained. The network training procedure is described in Section 6. In Section 7, simulation results are given. Finally, in Section 8, a comparison of the structures is evaluated.

2. Literature overview

There are many studies related to STLF in the literature. Most of these studies focus on artificial intelligence methods and hybrid methods. Khotanzad et al. forecasted 24-hour loads for a region in the United States using 6-month hourly load data with ANN [2]. Temperature and humidity data were used as independent variables in their study. Azadeh et al. used ANN to forecast 24-hour loads for Iran for the years 2003–2005 [4]. Temperature data was used as an independent variable in the study, and different networks were constructed for each season. Gontar and Hatziargyriou studied 48-hour-ahead load forecasting for Crete using RBF NN [8] without independent variables. Dongziao and Jie used day type, load, maximum–minimum temperature, and precipitation data of 16 September 2009 to forecast 24-hour loads for 17 November 2009 with RBF NN [7]. Xu et al. forecasted 24-hour-ahead loads for Xi'an, China, using temperature and load data with SVM [13]. Jain and Satish used temperature data as the independent variable in their study of 24-hour-ahead load forecasting with SVM [10]. Lu and Zhou used load and weather data with PSO-determined parameters of RBF NN for 24-hour load forecasting for a province in China [11]. Kim et al. used historical load data of the years

1990–1995 with ANN and FL to forecast hourly loads of specific days of the years 1996–1997 for Korea [21]. Song et al. intended to improve the estimations of that study using 20-year historical load data with the fuzzy linear regression method [22]. He et al. forecasted 24-hour loads for Hebei, China, for the year 2002, using load, temperature, humidity, and rainfall data with FL-based ANN [9].

There are few STLF studies using only analytical methods, while these methods are widely used in hybrid methods. Mu et al. studied 7-day-ahead load forecasting for Hainan, China using the similar day method [12]. The input data were chosen as load data, weather conditions, temperature data, day type, sociological conditions, and day difference in their study. Nalbant et al. forecasted monthly loads for Kutahya, Turkey, for the years 2005–2009 using LES without an independent variable [17]. Sumer et al. did not use any independent variable in their study of monthly load forecasting using ARIMA, SARIMA, and regression methods [18]. Ceylan and Demiroren used temperature and load data of the years 2002–2003 to forecast 24-hour loads of Gölbaşı, Turkey, with ANN and regression methods [5]. Yalçınöz et al. forecasted month-ahead loads for the years 2001–2004 using historical load data of the years 1991–2001 with ANN back propagation algorithm and moving average method [20]. Chen et al. forecasted 72-hour loads for Guizhou, China, using LES, SVM, and wavelet transform. Temperature data were used as the independent variable in their study [6]. Gao and Tsoukalas estimated 24-hour-ahead load demand using only historical load data with neural-wavelet methodology [16]. Pandey et al. did 24- and 168-hour-ahead load forecasting for a region in Canada using time series analysis and fuzzy neural networks together [1]. Temperature data were used as an independent variable in their study. Taylor and McSharry studied 24-hour-ahead load forecasting using ARIMA modeling, AR modeling, principal component analysis (PCA), and Holt–Winters exponential smoothing [19]. An independent variable was not used in their study. Chen et al. used the similar day method, wavelet transform, and ANN for 24-hour-ahead load forecasting [15]. Wind-chill temperature, humidex, cloud cover, precipitation, and wind speed were chosen as independent variables in their study. Zhu et al. used EMD and SVM together for 24-hour-ahead load forecasting for the day 20 June 2005 for Hubei, China [14]. In their study, historical load data were decomposed into intrinsic mode functions (IMF). Estimation results were achieved by different SVM models for each temperature data-inserted-IMF. Information about training data is not clear in their study.

3. Methodology

3.1. Wavelet transform

Wavelet transform is a signal analysis method based on Fourier transform. Continuous wavelet transform (CWT) was developed as an alternative to Fourier and short-time Fourier transforms to determine the frequency components of the signal at the desired time range in different-sized areas [23]. CWT is obtained by the convolution of the signal to be analyzed and the scaled (a) and shifted (b) versions of the mother wavelet function (Ψ), as shown in Eq. (1).

$$CWT(a, b) = \int_{-\infty}^{\infty} f(t) \cdot \frac{1}{\sqrt{a}} \cdot \Psi\left(\frac{t-b}{a}\right) \cdot dt. \quad (1)$$

Discrete wavelet transform (DWT) is a filter bank that decomposes the signal into its low- and high-frequency components. Transform continues until the desired level is reached by reducing the sample number to half at each level. The signal is decomposed into coefficients labeled as approximation (cA) for low-frequency components, and details (cD) for high-frequency components in the first level of transformation. It then

continues decomposing the approximations. Approximation and detail coefficients are computed using Eq. (2) and Eq. (3), respectively. For a better understanding of DWT, a third-order DWT is shown in Figure 1.

$$cA_j = \sum_{-\infty}^{\infty} f(n) \cdot \phi_{j,k}(n) = \sum_{-\infty}^{\infty} f(n) \cdot \frac{1}{\sqrt{2^j}} \cdot \phi\left(\frac{n - k \cdot 2^j}{2^j}\right), \tag{2}$$

$$cD_j = \sum_{-\infty}^{\infty} f(n) \cdot \Psi_{j,k}(n) = \sum_{-\infty}^{\infty} f(n) \cdot \frac{1}{\sqrt{2^j}} \cdot \Psi\left(\frac{n - k \cdot 2^j}{2^j}\right). \tag{3}$$

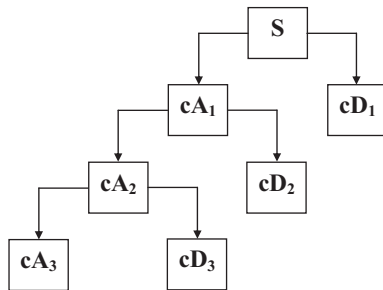

Figure 1. Third-order separation with DWT.

3.2. Radial basis function neural networks

RBF NN performs better than other neural networks in function approximation problems using fewer parameters [24]. RBF NN consists of 2 layers: a radial layer and a linear layer. In the radial layer, weight function is the Euclidian distance between the inputs and the weight neurons. The region of weight neurons in RBF NN is determined by the user with a spread constant, and the number of weight neurons is defined by the number of inputs. Net input function is computed by the multiplication of the weight function and the bias. Bias is fixed to 1 in RBF NN. The radial layer uses radbas transfer function and output layer uses purelin in MATLAB. The structure of RBF NN is shown in Figure 2.

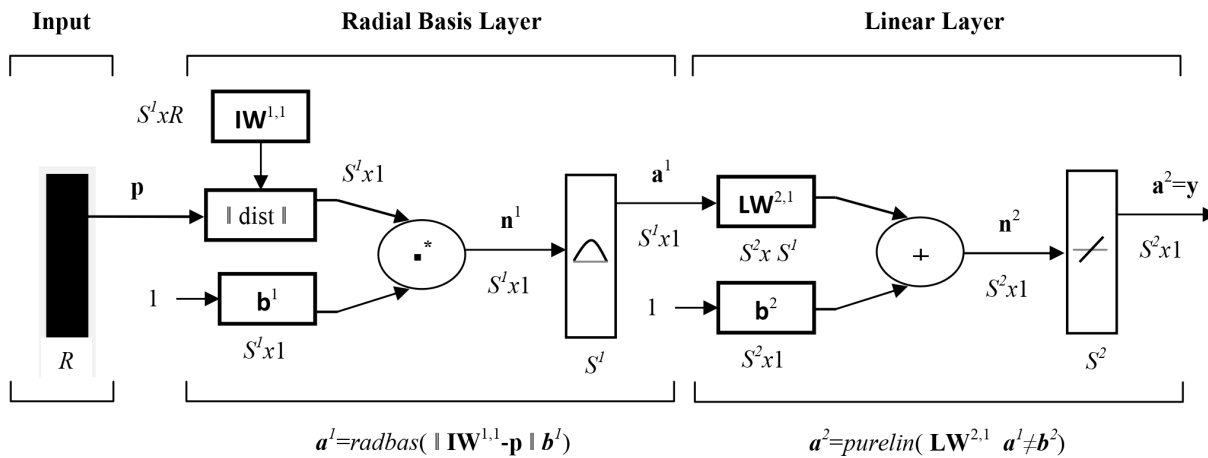

Figure 2. Structure of RBF NN.

3.3. Empirical mode decomposition

As an alternative for wavelets, EMD transform depends on high (detail) and low (trend) frequency decomposition [25]. This decomposition shows similarities to wavelet transform except in stopping criteria. Decomposition stops when maximum and minimum points do not exist. EMD is a completely data-driven transform without analytical analysis. High-frequency components at each level are named intrinsic mode function (IMF).

EMD transform follows the steps of identifying all extremes of $x(t)$, interpolating between minima (resp. maxima), ending up with some envelope $e_{min}(t)$ (resp. $e_{max}(t)$), computing the mean ($m(t) = (e_{min}(t) + e_{max}(t)) / 2$), extracting the detail ($d(t) = x(t) - m(t)$), and iterating on the residual $m(t)$ as the new $x(t)$ [25].

4. Input data selection and formulations

As mentioned in Section 1, load demand changes with meteorological, economic, sociological, and demographic condition changes. Therefore, independent variables (population; meteorological variables like temperature, humidity, precipitation; sociological variables including local holidays; and economic variables such as gross domestic price, imports, exports) must be taken into consideration in load forecasting studies. Temperature data are frequently used in STLF studies in the literature. In contrast to regional estimations, it is difficult to obtain effective temperature data for large-scale studies such as countrywide estimations. Consequently, short-term load forecasting without temperature data is attempted in this study.

Another factor that affects load demand characteristics is local holidays, such as New Year, national, and regional holidays. Hence, it is quite difficult to form a common structure for local holidays and normal days. For this reason, it is necessary for local holidays to be substituted with another structure or be removed from the forecasting study. In this study, local holidays' historical load data are changed into normal day characteristics using Eq. (4), and the estimation results of these days are not included in MAPEs.

$$(data)'_{LH} = \frac{\left| \sum_{d=1}^7 ((data)_{LH} - (data)_d) + \sum_{d=1}^7 ((data)_{LH} + (data)_d) \right|}{2} \times (data)_d \quad (4)$$

The terms LH and d in Eq. (4) refer to local holiday and day index, respectively.

It is already known that load demand varies seasonally from the studies related to load forecasting [1,4,8,15,19]. In addition, it is an observable fact that load demand also varies weekly. The analysis of historical load data clearly shows that load demand deviates with a rate determined by the previous 2 weeks' load consumptions. Therefore, in order to reduce estimation errors, a regulation for estimating loads is proposed in this study. Regulated load forecasting is achieved by inserting the deviation rate of weekly load consumptions into unregulated estimations. Formulations for weekly load consumption, deviation rate of weekly load consumption, and regulated load forecasting are given in Eq. (5), Eq. (6), and Eq. (7), respectively:

$$WC = \sum_{d=1}^7 \sum_{h=1}^{24} HC_h^d, \quad (5)$$

$$\Delta WC = \frac{WCLW}{WCSW}, \quad (6)$$

$$RLF = URLF + (\Delta WC - 1) \times URLF. \quad (7)$$

The terms WC , HC , d , h , ΔWC , $WCLW$, $WCSW$, RLF , and $URFL$ in the equations refer to weekly consumption, hourly consumption, day index, hour index, deviation rate of weekly consumption, weekly consumption of the first week before the forecasted day, weekly consumption of the second week before the forecasted day, regulated load forecasting, and unregulated load forecasting, respectively.

5. STLF procedure

STLF procedure consists of 4 structures: ANN, wavelet transform and ANN, wavelet transform and RBF NN, and EMD and RBF NN. To test the structures, 24-hour-ahead load forecasting for Turkey for 2009–2010 with Turkey's historical hourly load data of 2009–2010 obtained from TEIAS is used. MATLAB Neural Networks Toolbox and Wavelet Toolbox are used for the structures. A block diagram of the STLF procedure is shown in Figure 3 and all structures are explained in detail in the following subsections.

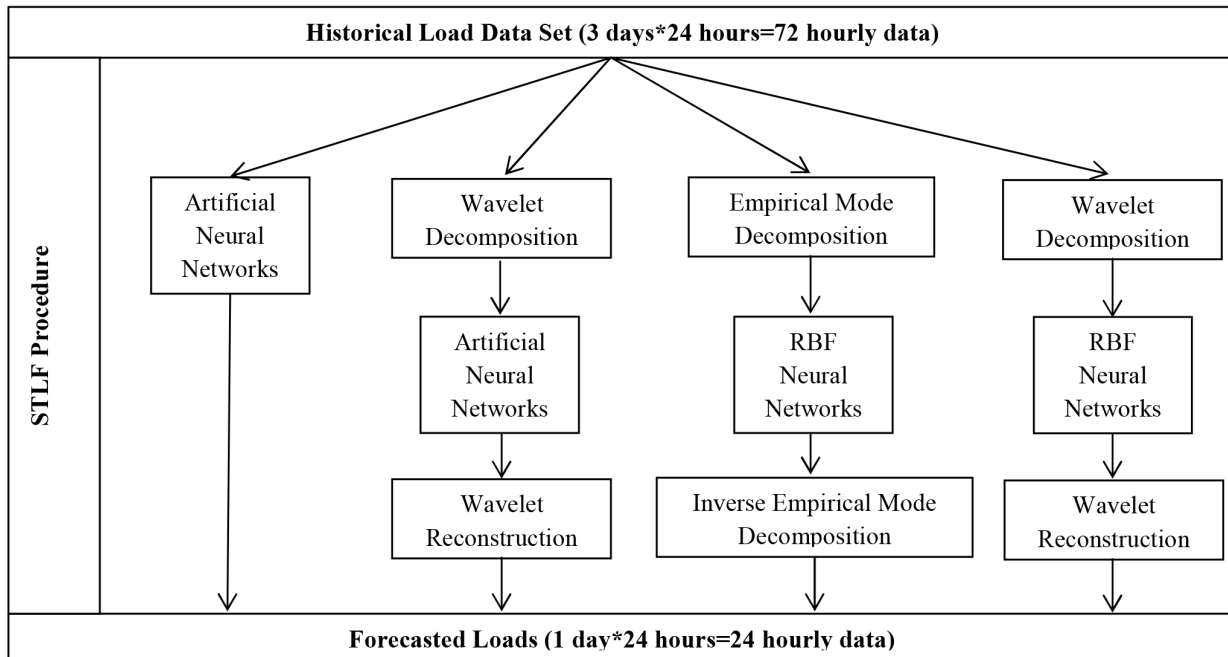

Figure 3. Block diagram of STLF procedure.

5.1. Structure 1: ANN

A 3-layered feed-forward back propagation neural network with a zero-error-goal neural network is used in this structure. The neuron number in the hidden layer was selected to be 10 by trial and error. Three days' hourly load data before the forecasted day are used to get 24-hour forecasted loads.

5.2. Structure 2: WT and ANN

ANN structure is a good function approximator, but it is hard for it to approximate if the inputs are close in input space. On the other hand, WT can represent frequency components of a signal in the time domain, and this helps ANN to approximate better. Hence, the same network mentioned above is used with WT in order to get more accurate results. In this case, input data are decomposed into low- and high-frequency components first. These coefficients are then used as inputs of ANN, and the coefficients of the forecasting day's load are obtained. By reconstructing the estimated coefficients, the 24-hour forecasted loads are obtained.

5.3. Structure 3: WT and RBF NN

It is already known that RBF NNs give more accurate results than ANNs for solving nonstationary problems. Hence, the structure above is reconstructed using RBF NN with spread constant 1 instead of ANN. The procedure is as described in Section 5.2.

5.4. Structure 4: EMD and RBF NN

In this structure, RBF NN is used with EMD. The input data are decomposed to IMFs, and the RBF neural network estimates the IMFs of the forecasted day. By summing these estimated IMFs, the 24-hour-ahead forecasted load is obtained.

Historical load data analysis shows that load demand mostly changes due to the 2 weeks previous to the forecasted day. Hence, networks in STLTF procedure are trained with the previous 2 weeks' hourly load data. The block diagram of network training is shown in Figure 4. The term d in Figure 4 is the forecasted day.

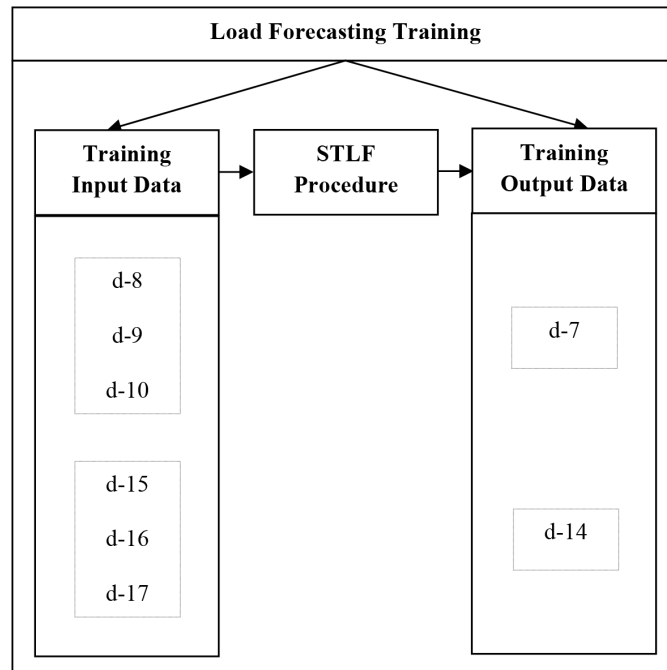

Figure 4. Block diagram of network training.

ANN structure is trained with hourly load data while WT and ANN and WT and RBF NN structures are trained with wavelet coefficients, and EMD and RBF NN structure is trained with IMFs. ANN is trained with the Levenberg–Marquardt function, and RBF NN is trained with radbas. It must be noted that ANN gives different forecast results for each training stage because of random initial weight values for neurons.

6. Simulation results

Turkey's historical hourly load data, obtained from TEIAS, of 1 December 2008 to 31 December 2010 are used for the proposed procedure, to produce Turkey's 24-hour-ahead load forecasting for the years 2009–2010. Simulation is performed via the user interface AI-STLTF created using the MATLAB GUI. The interface allows the user to select any of the structures proposed for the desired forecasting date using the imported historical load data. It then draws the curves of forecasted loads versus real load data for both unregulated and regulated

procedures with their MAPE values. Error percentages are computed as MAPE for all estimation results except for local holidays, and compared between all proposed structures. MAPE values are given as average daily MAPE and maximum daily MAPE. Daily MAPE and average daily MAPE are computed in Eq. (8) and Eq. (9), as D in Eq. (9) refers to the number of days without local holidays per year, respectively:

$$RLF = URLF + (\Delta WC - 1) \times URLF, \tag{8}$$

$$RLF = URLF + (\Delta WC - 1) \times URLF. \tag{9}$$

As an illustration, unregulated and regulated load curves of 27 February 2009 estimated by WT and RBF NN structure with AI-STLF are shown in Figure 5.

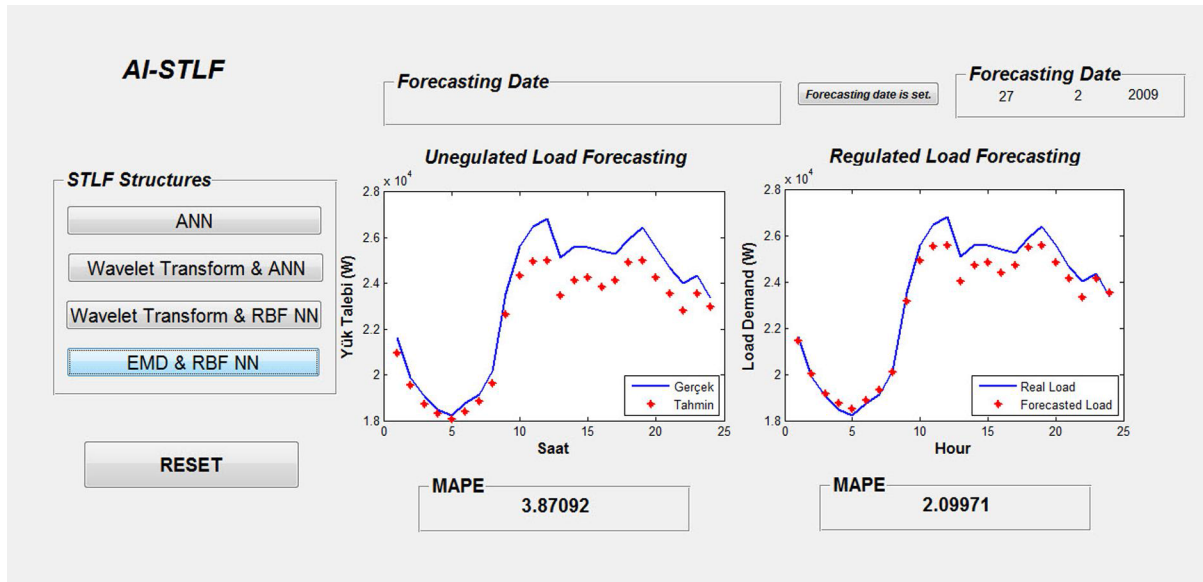

Figure 5. AI-STLF.

Table 1. MAPE values for the year 2009.

2009	ANN	Wavelet Transform and ANN	Wavelet Transform and RBF NN	EMD and RBF NN
Average Daily MAPE (Unregulated)	3.6735	3.7296	2.8955	3.5155
Maximum Daily MAPE (Unregulated)	10.9531	15.7200	10.1784	12.4950
Average Daily MAPE (Regulated)	3.3279	3.3459	2.9340	2.6686
Maximum Daily MAPE (Regulated)	11.9370	20.4328	11.5731	12.7550

Tables 1 and 2 show daily average and daily maximum MAPE values of both regulated and unregulated estimations for the years 2009 and 2010, respectively. These tables show that WT and RBF NN gives the minimum average daily MAPE values for unregulated estimations, and EMD and RBF NN gives the minimum average daily MAPE values for regulated estimations. Regulated average daily MAPE values obtained by EMD and RBF NN are lower than the unregulated average daily MAPE values obtained by WT and RBF NN.

Table 2. MAPE values for the year 2010.

2010	ANN	Wavelet Transform and ANN	Wavelet Transform and RBF NN	EMD and RBF NN
Average Daily MAPE (Unregulated)	3.8104	4.1859	2.9919	3.6346
Maximum Daily MAPE (Unregulated)	9.5459	15.2228	9.7173	11.1660
Average Daily MAPE (Regulated)	3.3983	3.5704	3.0351	2.6424
Maximum Daily MAPE (Regulated)	9.1770	14.8118	13.9602	8.1421

In Table 1, it can be seen that the lowest maximum daily MAPE for 2009 is achieved by WT and RBF NN in unregulated forecasting, while ANN gives the most accurate results in regulated forecasting for 2010, as shown in Table 2.

In accordance with the results, as the best forecasting structure in the study, regulated daily MAPEs for years 2009–2010, with local holidays’ forecasting included, achieved by EMD and RBF NN is shown in Figure 6.

As an example of the proposed procedure, 24-hour-ahead regulated and unregulated forecasted load curves and the real load curve of the day 27 February 2009 (Friday) are given in Figures 7 and 8, respectively. MAPE values for this day are given below.

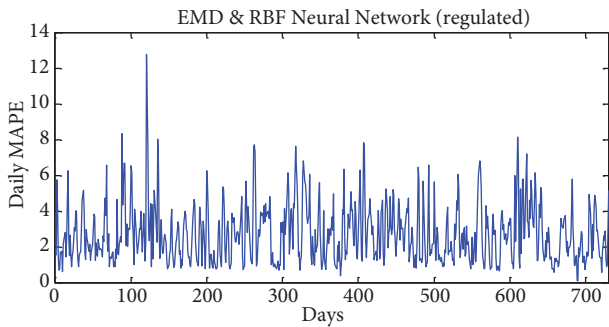

Figure 6. Daily regulated MAPEs for the years 2009–2010.

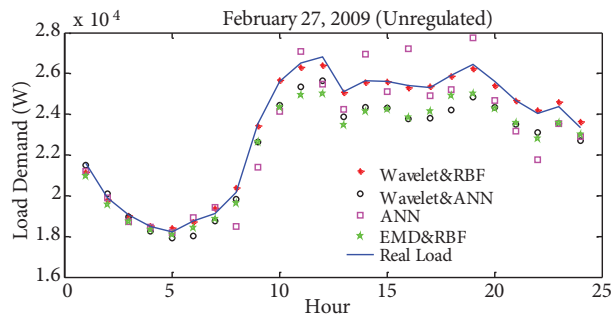

Figure 7. Unregulated forecasted loads vs. real load (MAPE-wavelet and RBF = 3.8709).

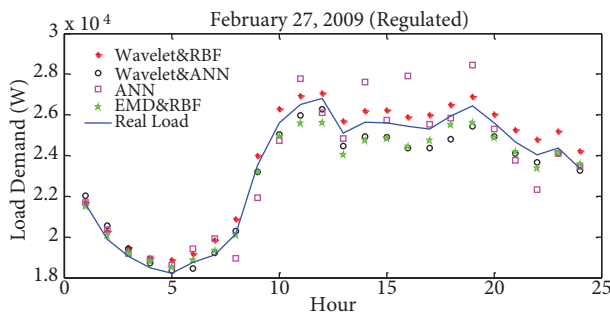

Figure 8. Regulated forecasted loads vs. real load (MAPE-wavelet and RBF = 2.0997).

7. Conclusion

In this study, 24-hour-ahead load forecasting without weather data for Turkey for 2009–2010 with ANN, WT and ANN, WT and RBF NN, and EMD and RBF NN is implemented. It is hard to define one temperature or other weather values for a large region; hence, forecasting without these data is proposed. In addition to forecasts, to decrease MAPE values, a regulation is defined using the previous 2 weeks' load demands.

The structures ANN and RBF NN are good function approximators. WT and EMD help these approximators by decomposing signals into higher and more useful dimensions. It must be noted that ANN gives different forecast results for each training stage because of random initial weight values for neurons.

Error results in the study show remarkable success for all structures without using meteorological data. According to MAPE values, WT and RBF NN and EMD and RBF NN can be used to forecast for a large region without meteorological data. The decision about choosing an appropriate structure can be made according to the criteria average daily MAPE or maximum daily MAPE. If the peak error is important, maximum daily MAPE and a structure that gives good results for this error type must be taken into consideration. If the overall error is important, daily average MAPE and a structure that gives good results for this error type must be taken into consideration. This decision is up to the end user.

All the structures and forecasting procedures are based on artificial intelligence. In future studies, analytical methods will be used and analytical and artificial intelligence methods will be compared. Furthermore, a load forecasting procedure for local holidays will be proposed.

References

- [1] A.S. Pandey, D. Singh, S.K. Sinha, "Intelligent hybrid wavelet models for short-term load forecasting", *IEEE Transactions on Power Systems*, Vol. 25, pp. 1266–1273, 2010.
- [2] A. Khotanzad, R. Afkhami-Rohani, T.L. Lu, A. Abaye, M. Davis, D.J. Maratukulam, "ANNSTLF: a neural-network-based electric load forecasting system", *IEEE Transactions on Neural Networks*, Vol. 8, pp. 835–846, 1997.
- [3] M.S. Kiran, E. Ozceylan, M. Gunduz, T. Paksoy, "A novel hybrid approach based on particle swarm optimization and ant colony algorithm to forecast energy demand of Turkey", *Energy Conversion and Management*, Vol. 53, pp. 75–83, 2012.
- [4] A. Azadeh, S.F. Ghadrei, B. Pourvalikhan Nokhandan, "Short term load forecasting by ANN", *Hybrid Intelligent Models and Applications*, pp. 39–43, 2009.
- [5] G. Ceylan, A. Demiroren, "Yapay sinir ağları ile Gölbaşı bölgesinin kısa dönem yük tahmini", *ELECO 2004*, pp. 103–107, 2004.
- [6] Q.S. Chen, X. Zhang, S.H. Xiong, X.W. Chen, "Short-term load forecasting with least squares support vector machines and wavelet transform", *Proceedings of the Seventh International Conference on Machine Learning and Cybernetics Kunming*, pp. 1425–1429, 2008.
- [7] N. Dongxiao, T. Jie, "Improved RBF network applied to short-term load forecasting", *ICSESS 2011*, pp. 864–867, 2011.
- [8] Z. Gontar, N. Hatzigiorgiou, "Short term load forecasting with radial basis function network", *IEEE Porto Power Tech. Conference*, 2001.
- [9] Y.J. He, Y.C. Zhu, D.X. Duan, W. Sun, "Application of neural network model based on combination of fuzzy classification and input selection in short term load forecasting", *Proceedings of the Fifth International Conference on Machine Learning and Cybernetics*, pp. 3152–3156, 2006.
- [10] A. Jain, B. Satish, "Integrated architecture for short-term load forecasting using support vector machines", *NAPS '08*, pp. 1–8, 2008.

- [11] N. Lu, J. Zhou, “Particle swarm optimization-based RBF neural network load forecasting model”, APPEEC 2009, pp. 27–31, 2009.
- [12] Q. Mu, Y. Wu, X. Pan, L. Huang, X. Li, “Short-term load forecasting using improved similar days method”, APPEEC 2010, pp. 1–4, 2010.
- [13] H. Xu, J.H. Wang, S.Q. Zheng, “Online daily load forecasting based on support vector machines”, Proceedings of the Fourth International Conference on Machine Learning and Cybernetics Guangzhou, pp. 3985–3990, 2005.
- [14] Z. Zhu, Y. Sun, H. Li, “Hybrid of EMD and SVMs for short-term load forecasting”, ICCA 2007, pp. 1044–1047, 2007.
- [15] Y. Chen, P.B. Luh, C. Guan, Y. Zhao, L.D. Michel, M.A. Coolbeth, P.B. Friedland, S.J. Rourke, “Short-term load forecasting: similar day-based wavelet neural networks”, IEEE Transactions on Power Systems, Vol. 25, pp. 322–330, 2010.
- [16] R. Gao, L.H. Tsoukalas, “Neural-wavelet methodology for load forecasting”, Journal of Intelligent and Robotic Systems, Vol. 31, pp. 149–157, 2001.
- [17] A. Nalbant, Y. Aslan, C. Yasar, “Kütahya ili için elektrik puant yük tahmini”, Elektrik Elektronik Bilgisayar Mühendisliği 11. Ulusal Kongresi, Vol. 1, pp. 211–214, 2005.
- [18] K.K. Sumer, O. Göktas, A. Hepsag, “The application of seasonal latent variable in forecasting electricity demand as an alternative method”, Energy Policy, Vol. 37, pp. 1317–1322, 2007.
- [19] J.W. Taylor, P.E. McSharry, “Short-term load forecasting methods: an evaluation based on European data”, IEEE Transactions on Power Systems, Vol. 22, 2213–2219.
- [20] T. Yalcinoz, S. Herdem, U. Eminoglu, “Yapay sinir ağları ile Niğde bölgesinin elektrik yük tahmini”, ELECO 2002, pp. 25–29, 2002.
- [21] K.H. Kim, H.S. Youn, Y.C. Kang, “Short-term load forecasting for special days in anomalous load conditions using neural networks and fuzzy inference method”, IEEE Transactions on Power Systems, Vol. 15, pp. 559–565, 2000.
- [22] K.B. Song, Y.S. Back, D.H. Hong, G. Jang, “Short-term load forecasting for the holidays using linear regression method”, IEEE Transactions on Power Systems, Vol. 20, pp. 96–101, 2005.
- [23] K. Ari, S. Ozen, O.H. Colak, Dalgacık Teorisi (Wavelet) Matlab Uygulamaları İle, Palme Publishing, 2008.
- [24] S. Haykin, Neural Networks: A Comprehensive Foundation, Prentice Hall, 1998.
- [25] G. Rilling, P. Flandrin, P. Gonçalvès, “On empirical mode decomposition and its algorithms”, NSIP-03, 2003.