

Optimal Placement of TCSC SSSC and UPFC on Power Systems for Maximum Loading Parameter and Minimum Line Losses

M. Kenan DOSOGLU*, Ali OZTURK*, Gokhan POYRAZ⁺, Salih TOSUN*, Ismail ERCAN*

**Electric-Electronic Engineering Department, Duzce University Technology Faculty,
81620 Duzce, Turkey*

kenandosoglu, aliozturk, salihtosun, ismailercan@duzce.edu.tr

*⁺Electric-Electronic Engineering Department, Bilecik Seyh Edebali University, Engineering Faculty,
11210 Bilecik, Turkey*

gokhan.poyraz@bilecik.edu.tr

Abstract— In this study, effects of Thyristor Controller Series Compensator (TCSC) Static Synchronous Series Compensator (SSSC) and Unified Power Flow Controller (UPFC) on power systems are investigated. In 65 buses system, effects of the points where voltage stability is Maximum Loading Parameter (MLP) and the Minimization Line Losses (MLL) are investigated by FACTS devices. Relations between voltage and maximum load parameters and power losses between the lines are illustrated by figure. According to the acquired results; UPFC are more efficient than SSSC and TCSC in terms of both voltage stability and line losses.

Keywords— SSSC, TCSC, UPFC, MLP, MLL

I. INTRODUCTION

As a result of increasing demand of the consumers and reconstruction of the power sector, the working conditions of the power systems became harder. Problems that may occur in this working conditions cause system instability. For high capacity transmission line and so as to decrease line losses Flexible AC Transmission System (FACTS) devices are used [1]. FACTS devices are generally consist of Static Synchronous Compensator (STATCOM), Static Var Compensator (SVC), Static Synchronous Series Compensator (SSSC), Thyristor Controller Series Compensator (TCSC) and Unified Power Flow Controller (UPFC). This study is emphasized on SSSC, TCSC and UPFC. If we review the previous study in literature; in different modes, the effects of the transient stability and small signal stability of SSSC which has series converter in are analyzed. It is seen that with the use of SSSC in power systems it has effects on voltage and phase angle [2-3]. Optimum control is provided to improving the energy functions with SSSC in power systems. It's success on critical clear angle and elimination of the harmonics is observed [4-5]. Another area which SSSC is used is Power System Stabilizer (PSS). SSSC gives very well results in c of inter-area oscillations in various load distributions [6-7]. Trajectory Sensitivity Analysis (TSA) is investigated with TCSC which has simpler construction than SSSC in various

types of fault. In power systems depends on the fault states optimum placement of TCSC is determined [8]. It is seen that TCSC is efficient in a transient stability situations such as line block out that may occur [9]. As TCSC is effective in power flow, it is seen after the study that TCSC is used efficiently in the optimal load flow analysis [10]. TCSC progresses the bus voltage profiles with improving different programming techniques [11]. In a similar way, TCSC protects the power systems against the sequential distributions with improving different control methods [12]. It is observed that UPFC which has both series and parallel converter circuit is used effectively in first swing stability analysis [13]. In UPFC by series converter circuit line active and reactive power flow, by parallel converter the bus voltage and reactive power control is provided successfully [14-15]. In this study, at minimizing voltage instability and line losses processes optimal places of SSSC, TCSC and UPFC are investigated depending on the different approaches. In 65 bus system, maximum loading parameter, bus voltage profiles and changes in line losses are investigated.

II. THYRISTOR CONTROLLER SERIES COMPENSATOR (TCSC)

Thyristor Controller Series Compensator (TCSC) is connected to transmission line in series and consist of Thyristor Controller Reactor (TCR) and Thyristor Switched Capacitor (TSC). Generally is used for the aim to current control in transmission lines. TCSC control and circuit model are seen in Fig. 1.

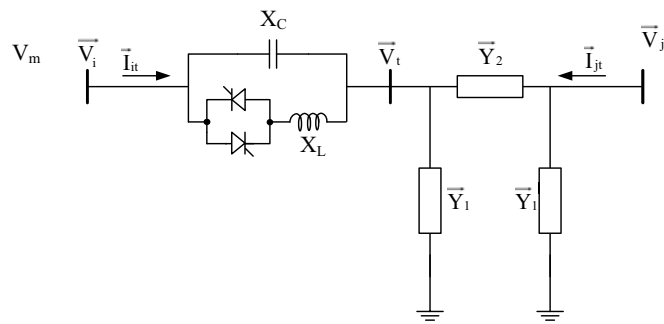

Fig. 1 TSSC Models

The difference between reference current and measured current value is considered by unit of controller triggering angles of thyristors are determined. TCSC system control is expressed by the following equation;

$$P + V_i V_j B_e \sin(\delta_i - \delta_j) = 0 \quad (1)$$

$$-V_i^2 B_e + V_i V_j B_e \cos(\delta_i - \delta_j) - Q_i = 0 \quad (2)$$

$$-V_j^2 B_e + V_i V_j B_e \cos(\delta_i - \delta_j) - Q_j = 0 \quad (3)$$

$$B_e - B_e(\alpha) = 0 \quad (4)$$

$$P + jQ_i - IV_i = 0 \quad (5)$$

where, P active power, V_i i bus voltage, V_j j bus voltage, B_e susceptance, δ_i i bus voltage angle, δ_j j bus voltage angle, Q_i i bus reactive power, I measurement current, $B_e(\alpha)$ thyristor depend new susceptance [16]. TCSC current and admittance equation 6 and equation 7 are seen.

$$I_{it} = \frac{Y_{TCSC}(Y_i + Y_j)V_i - Y_i V_j}{Y_{TCSC} + Y_i + Y_j} \quad (6)$$

$$Y_{TCSC} = \frac{1}{jX_{TCSC}} \quad (7)$$

III. STATIC SYNCHRONOUS SERIES COMPENSATOR (SSSC)

Static Synchronous Series Compensator (SSSC) is consist of voltage source converter (VSC) circuit which is connected series to the transmission line. Current control of transmission line provided by DC link voltage. SSSC control and circuit model are illustrated in Fig. 2.

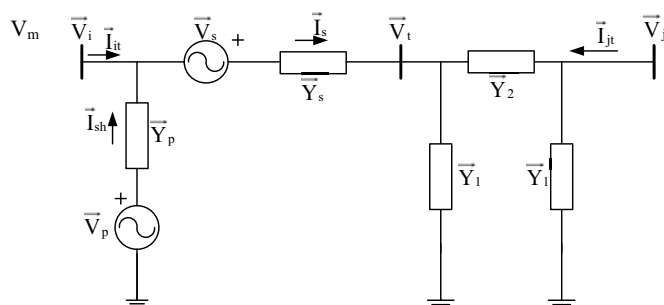

Fig. 2 SSSC Models

The difference between reference current V_{dc} and measured current V_{dcref} value is considered by unit of controller triggering angles of thyristors are determined. SSSC system control is expressed by the following equation [17].

$$I - I_{ref} = 0 \quad (8)$$

$$V_{dc} - V_{dcref} = 0 \quad (9)$$

$$P - V_{dc}^2 / RC - RI^2 = 0 \quad (10)$$

where, I measurement current, I_{ref} reference current, V_{dc} DC link voltage, V_{dcref} reference DC voltage, P active power, C capacitor, R resistance.

SSSC current and admittance equations are seen at 11 and 12.

$$I_{it} = \frac{Y_{SSSC}(Y_i + Y_j)V_i - Y_i V_j}{Y_{SSSC} + Y_i + Y_j} \quad (11)$$

$$Y_{TCSC,SSSC} = \frac{1}{jX_{SSSC}} \quad (12)$$

IV. UNIFIED POWER FLOW CONTROLLER (UPFC)

UPFC is consist of series and parallel voltage source converter (VSC) circuits. With combination of STATCOM and SSSC, to transmission line; to series bus are connected to parallel. They made the active and reactive power arrangement in system [18]. Control and circuit model of UPFC are illustrated in Fig. 3.

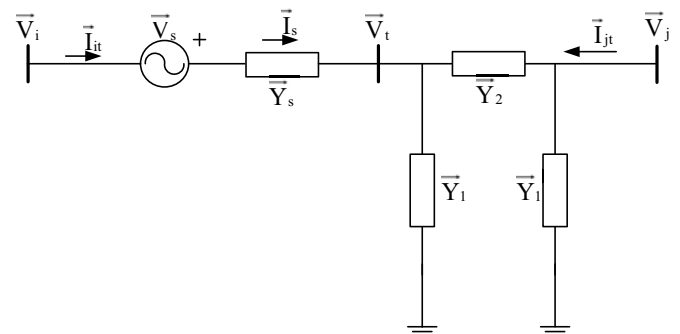

Fig. 3 UPFC Models

Depending on the V_{dc} triggering of series and parallel converters are provided by comparing both current and voltage references. In that way, current of line and bus voltage can be controlled. STATCOM system control can be expressed by the following equations.

Depending on this, the visible power between the lines is expressed as;

$$V - V_{ref} + XI = 0 \quad (13)$$

$$V_{dc} - V_{dcref} = 0 \quad (14)$$

$$P - V_{dc}^2 / RC - RI^2 = 0 \quad (15)$$

If we rewrite the SSSC system control with UPFC;

$$I - I_{ref} = 0 \quad (16)$$

$$V_{dc} - V_{dcref} = 0 \quad (17)$$

$$P - V_{dc}^2 / RC - RI^2 = 0 \quad (18)$$

Voltage equations of UPFC are expressed as;

$$V_i = \frac{Y_s(V_i + V_s) + Y_1 V_j}{Y_s + Y_1 + Y_2} \quad (19)$$

V. MAXIMUM LOADING PARAMETER AND LINE LOSSES MINIMIZATION

Studies The maximum loading parameter is provided by adding the FACTS devices on the system. Relation between voltage and maximum loading parameter is illustrated in Fig. 4 [19].

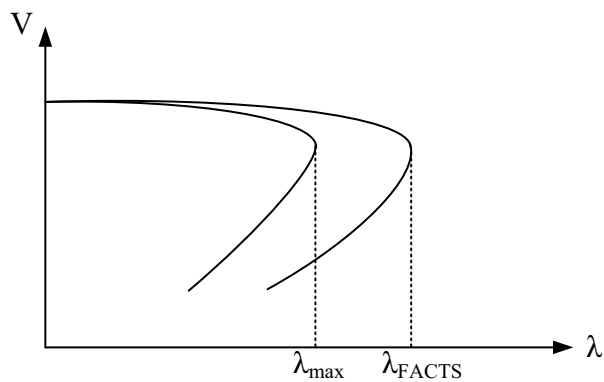

Fig. 4 Relation Voltage-Maximum Loading Parameter with FACTS

In power system, relation between the active power and reactive power maximum loading parameter is expressed as;

$$P_{gi} = P_0(1 + \lambda) \quad (20)$$

$$Q_{gi} = Q_0(1 + \lambda) \quad (21)$$

where, P_{gi} new active power after adding FACTS, P_0 initial active power and λ maximum loading parameter index. If we express the active and reactive power losses between the lines in power systems;

$$P_{lossij} = I_{ij}^2 \times r_{ij} \quad (22)$$

$$P_{lossji} = I_{ji}^2 \times r_{ji} \quad (23)$$

$$P_{netloss} = P_{lossij} - P_{lossji} \quad (23)$$

$$Q_{lossij} = I_{ij}^2 \times jX_{ij} \quad (24)$$

$$Q_{lossji} = I_{ji}^2 \times jX_{ji} \quad (25)$$

$$Q_{netloss} = Q_{lossij} - Q_{lossji} \quad (26)$$

After adding TCSC, SSSC and UPFC on power systems, there will be change in reactance value. After adding FACTS devices on power systems obtained new power losses expressions expressed as;

$$Q_{lossij} = I_{ij}^2 \times j(X_{ij} + X_{TCSC,SSSC,UPFC}) \quad (27)$$

$$Q_{lossji} = I_{ji}^2 \times j(X_{ji} + X_{TCSC,SSSC,UPFC}) \quad (28)$$

VI. SYSTEM ANALYSIS

In this study which is on 65 bus system in Turkey, optimum placement points of SSSC, TCSC and UPFC is found depending on where the line losses are minimum and where the maximum loading parameter takes the most proper value. 65 bus system is illustrated in Fig. 5 [20].

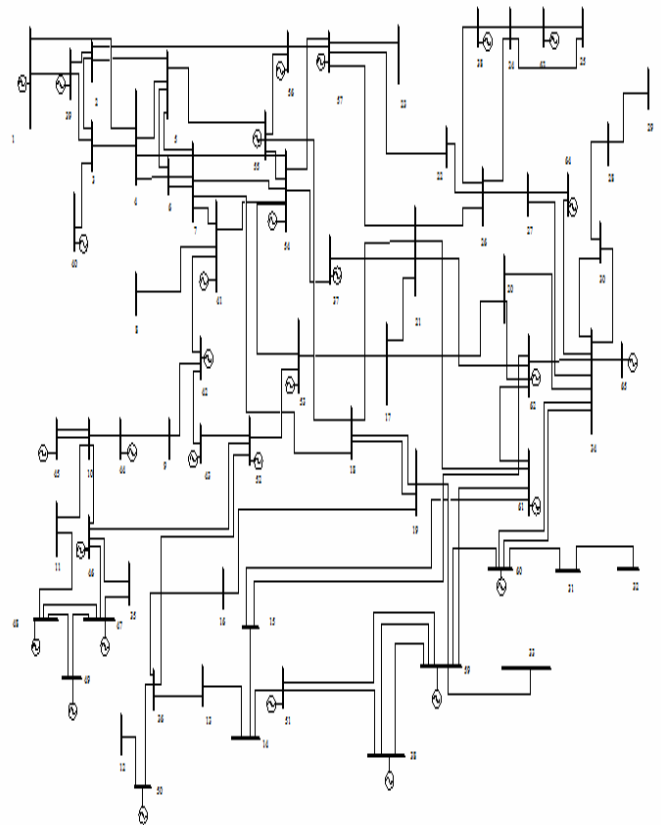

Fig. 5 65 Bus System

This system is consist of 1 slack bus, 28 bus generator and 35 load bus. Firstly, power flow analysis is made by 65 bus system. According to the voltage profiles, buses with very low voltage values are observed. Secondly, continuously power flow analysis is made by 65 bus system. As a result of

continuous power flow analysis maximum loading parameter of the system and total line loss data are obtained. 100 MVA TCSC, 100 MVA SSSC and 100 MVA UPFC are series connected between two bus which has lowest voltage value. Finally, approach analysis, FACTS devices are series connected to the buses with has most line losses. The effects on primarily TCSC, then SSSC and finally UPFC on both maximum loading parameter and on line loss are investigated [21].

VII. SIMULATION RESULTS

In 65 bus system, bus voltage profiles and maximum loading states are illustrated as a result of load flow in Fig. 6 and Fig. 7.

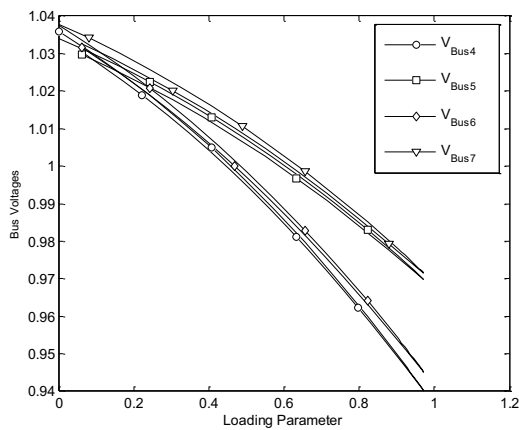

Fig. 6 Without FACTS 4, 5, 6, 7 Bus Loading Parameter

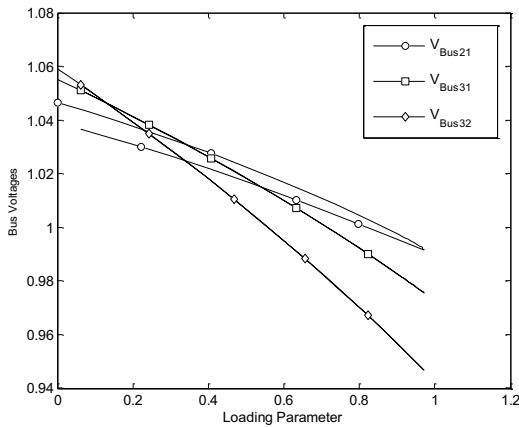

Fig. 7 Without FACTS 21, 31, 32 Bus Loading Parameter

As a result of load flow analysis, in 65 bus system the buses which have the lowest voltage profiles are 37 and 54 buses. Maximum loading parameter value is 0.97125. Except the buses which are connected to slack bus, lines which have most losses are 4 and 5. At the state when TCSC was connected to the buses which has the lowest voltage profiles, buses number 37 and 54, obtained voltage profile and maximum load ability are illustrated in Fig. 8 and Fig. 9.

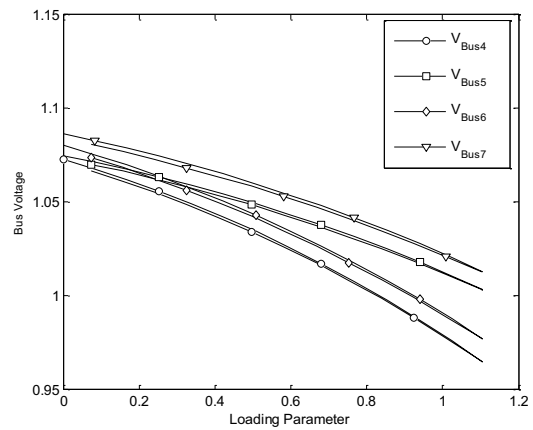

Fig. 8 With TCSC 4, 5, 6, 7 Bus Loading Parameter

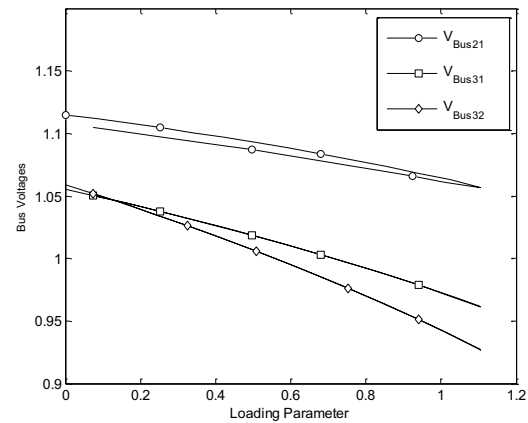

Fig. 9 With TCSC 21, 31, 32 Bus Loading Parameter

After replacing TCSC between bus number 37 and 54, system maximum loading parameter is increased to 1.1059. At the state when SSSC was connected to the buses which has the lowest voltage profiles, buses number 37 and 54, obtained voltage profile and maximum load ability are illustrated in Fig. 10, and Fig. 11.

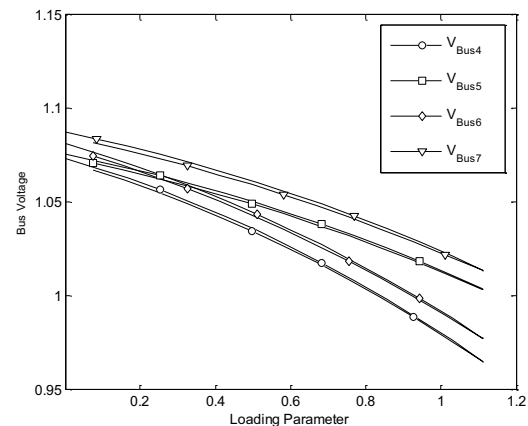

Fig. 10 With SSSC 4, 5, 6, 7 Bus Loading Parameter

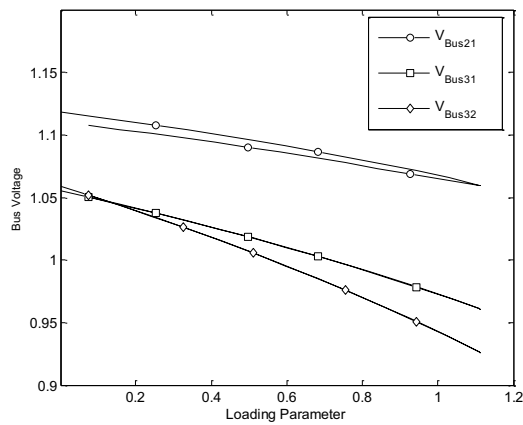

Fig. 11 With SSSC 21, 31, 32 Bus Loading Parameter

After replacing SSSC between bus number 37 and 54, system maximum loading parameter is increased to 1.1111. At the state when UPFC was connected to the buses which has the lowest voltage profiles, buses number 37 and 54, obtained voltage profile and maximum load ability are illustrated in Fig. 12 and Fig. 13.

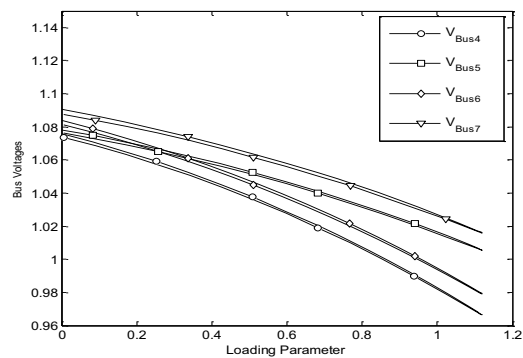

Fig. 12 With UPFC 4, 5, 6, 7 Bus Loading Parameter

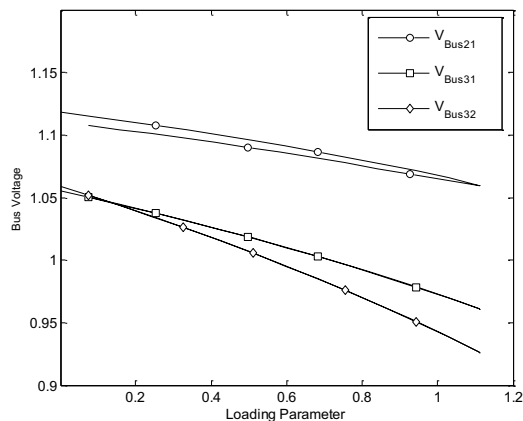

Fig. 13 With UPFC 21, 31, 32 Bus Loading Parameter

After replacing UPFC between bus number 37 and 54, system maximum loading parameter is increased to 1.1187. As a result, with the usage of TCSC, SSSC and UPFC maximum loading parameter and line losses without having the FACTS devices are illustrated in Table 1. As a result of the table, in UPFC maximum loading parameter takes the greatest value than in TCSC and SSSC. Besides in terms of total power losses, it is seen that UPFC is smaller than other devices.

 TABLE I
 MAXIMUM LOADING PARAMETER AND TOTAL TRANSMISSION LOSSES

	Variable	MLP	Total Active Power Loss	Total Active Power Loss
37-54 Between Transmission Line	Without FACTS	0.97125	0.0851	0.0602
	With TCSC	1.1059	0.0784	0.0587
	With SSSC	1.1111	0.0752	0.0562
	With UPFC	1.1187	0.0692	0.0503
4-5 Between Transmission Line	Without FACTS	0.97125	0.0851	0.0602
	With TCSC	1.1024	0.0816	0.0596
	With SSSC	0.1095	0.0764	0.0573
	With UPFC	1.1156	0.0712	0.0521

VIII. CONCLUSIONS

In this study, In 65 bus system, effects of the points where voltage stability is maximum and the line losses are minimum are investigation by TCSC, SSSC and UPFC which are of FACTS devices. In terms of bus voltage profiles, UPFC is more successful on determination of the optimum place and maximum load parameter and minimizing the line losses than other FACTS. It is concluded that SSSC gives better results than TCSC. It is also seen that in terms of line losses determination of optimum place, UPFC gives best result. It is obviously demonstrated after the study that in both approaches, use of FACTS devices in power systems may be effective.

REFERENCES

- [1] T. Jain, S. N. Singh and S. C. Srivastava, "Dynamic ATC enhancement through optimal placement of FACTS controllers," *Electric Power Systems Research*, vol. 79, pp. 1473-1482, Nov. 2009.
- [2] F. A. L. Jowder, "Influence of mode of operation of the SSSC on the small disturbance and transient stability of a radial power system," *IEEE Transaction on Power Systems*, 20, pp. 935-942, May. 2005.
- [3] M. S. Castro, H. M. Ayres, V. F. Costa and L. C. P. Silva, "Impacts of the SSSC control modes on small-signal transient stability of power system," *Electric Power Systems Research*, 77, pp. 1-9, Jan. 2007.
- [4] U. Gabrijel, and M. Rafael, "Direct methods for transient stability assessment in power systems comprising controllable series devices," *IEEE Transaction on Power Systems*, 22, pp. 1116-1122, Sept. 2002.

- [5] M. E. Moursi, A. M. Sharaf and K. E. Arroudi, "Optimal control schemes for SSSC for dynamic series compensation," *Electric Power Systems Research*, 78, pp. 646-656, April 2008.
- [6] I. Ngamroo and W. Kongprawechnon, "A robust controller design of SSSC for stabilization of frequency oscillations in interconnected power systems," *Electric Power Systems Research*, 67, pp. 161-176, Dec. 2003.
- [7] M. R. Shakarami and A. Kazemi, "Assessment of effect of SSSC stabilizer in different control channels on damping inter-area oscillations," *Energy Conversion and Management*, 52, pp. 1622-1629, March 2011.
- [8] D. Chatterjee and A. Ghosh, "TCSC control design for transient stability improvement of a multi-machine power system using trajectory sensitivity," *Electric Power Systems Research*, 77, pp. 470-483, April 2007.
- [9] H. Besharat and S. A. Taher, "Congestion management by determining optimal location of TCSC in deregulated power systems," *Electrical Power and Energy Systems*, 30, pp. 563-568, Dec. 2008.
- [10] N. Acharya and N. Mithulananthan, "Locating Series FACTS Devices for Congestion Management in Deregulated Electricity Markets," *Electric Power Systems Research*, 77, pp. 352-360, March 2007.
- [11] G. Y. Yang, G. Hovland, R. Majumder and Z. Y. Dong, "TCSC allocation based on line flow based equations via mixed-integer programming," *IEEE Transaction on Power Systems*, 22, pp. 2262-2269, Nov. 2007.
- [12] A. M. Simoes, D. C. Savelli, P. C. Pellanda, N. Martins and P. Apkarian, "Robust design of a TCSC oscillation damping controller in a weak 500-kv interconnection considering multiple power flow scenarios and external disturbances," *IEEE Transaction on Power Systems*, 24, pp. 226-236, Feb. 2009.
- [13] E. Gholipour and S. Saadat, "Improving of transient stability of power systems using UPFC," *IEEE Transaction on Power Delivery*, 20, pp. 1677-1682, April 2005.
- [14] S. Kannan, S. Jayaran and M. M. A Salama, "Real and reactive power coordination for a unified power flow controller," *IEEE Transaction on Power Systems*, 19, pp. 1454-1461, Aug. 2004.
- [15] J. Y. Lui, Y. H. Song and P. A. Mehta, "Strategies for handling UPFC constraints in steady-state power flow and voltage control," *IEEE Transaction on Power Systems*, 15, pp. 566-571, May 2000.
- [16] T. Orfanogianni and R. Bacher, "Steady-state optimization in power systems with series FACTS devices," *IEEE Transaction on Power Systems*, 18, pp. 19-26, Feb. 2003.
- [17] J. Chen, T. T. Lie and D. M. Vilathgamuwa, "Damping of power system oscillations using SSSC in real-time implementation," *Electric Power and Energy Systems*, 26, pp. 357-364, June 2004.
- [18] A. Ajami, S. H. Hosseini, S. Khanmohammadi and G. B. Gharehpetian, "Modeling and control of C-UPFC for power system transient studies," *Simulation Modeling Practice and Theory*, 14, pp. 564-576, July 2006.
- [19] E. A. Leonidaki, G. A. Manos and N. D. Hatziargyriou, "An effective method to locate series compensation for voltage stability enhancement," *Electric Power Systems Research*, 74, pp. 73-81, April 2005.
- [20] U. Basaran, "Various power flow and economic dispatch analysis on 380 KV interconnected power system in Turkey," M. Eng. thesis, Natural Science Institute of Science, Anadolu University, Eskisehir, Turkey, 2004.
- [21] F. Milano, "An open source power system analysis toolbox", *IEEE Transactions on Power Systems*, vol.20, pp. 1199-1206, Aug. 2005.