





# VHDL-AMS-Based Modeling of an Asymmetric H-Type Half-Bridge Converter for Mutually Coupled SRM

*Karşıt Kuplajlı ARM İçin Asimetrik H Tipi Yarım Köprü Dönüştürücünün VHDL-AMS Tabanlı Modellenmesi*

Cihan Şahin<sup>1\*</sup> , Ayşe Ergün Amaç<sup>2</sup> , Mevlüt Karaçor<sup>3</sup> 

<sup>1</sup>Bilecik Şeyh Edebali University, Vocational School, Control Automation Program, Bilecik, Turkey

<sup>2</sup>Kocaeli Üniversitesi, Technology Faculty, Energy Systems Engineering, Kocaeli, Turkey

<sup>3</sup>Manisa Celal Bayar University, Hasan Ferdi Turgutlu Technology Faculty, Mechatronic Engineering, Manisa, Turkey

## Abstract

Nowadays, mutually coupled reluctance machine (MCSRМ), which produces further torque compare to classical switched reluctance machine (SRM), has acquired a deserving value and importance thanks to developing technology and control algorithm. While torque is produced through the changing of self-inductance at classical SRM, it depends on mutual inductance that occurs between phases at MCSRМ. Determination of the inductance and transferring of it to the converter model correctly are quiet important, since the machine torque has directly varied by inductance value. There are various methods on SRM drives modeling such as look-up table, manipulated by the variation of inductance value in the literature. However, exact modeling can be possible with transferring of the inductance values acquired from the machine static analysis to the model smoothly. In order to achieve that, it is proposed a “Very high-speed integrated circuit Hardware Description Language-Analog Mixed Signal” (VHDL-AMS) based modeling method for an asymmetric H-type half-bridge converter as a MCSRМ drive in this study. Mutual inductance values are calculated by VHDL-AMS, according to phase current and angle of the machine rotor. Consequently, inductance that varies depending upon the machine rotor position is determined by the proposed method dynamically.

**Keywords:** Switched reluctance machine, SRM, MCSRМ, VHDL-AMS

## Öz

Günümüzde, klasik Anahtarlamalı Relüktans makinasına (ARM) kıyasla daha fazla moment üreten Karşıt Kuplajlı Anahtarlamalı Relüktans Makinası (KKARM) gelişen teknoloji ve kontrol algoritması sayesinde hak ettiği değeri ve önemi kazanmıştır. Moment, klasik ARM’de öz-endüktansının değiştirilmesi yoluyla üretilirken, KKARM’deki fazlar arasında meydana gelen karşılıklı endüktansa bağlıdır. Makine momentinin doğrudan endüktans değeri ile değişmesinden dolayı, endüktansın saptanması ve sürücü modeline doğru şekilde aktarılması önemlidir. Literatürde, Look-up table gibi ARM sürücü modellemesinde kullanılan çeşitli yöntemler vardır. Makinanın statik analizinden elde edilen endüktans değerlerinin modele doğru bir şekilde aktarılmasıyla net bir modelleme mümkün olabilir. Bunu başarmak için, bu çalışmada KKARM sürücüsü olarak bir asimetrik H-tipi yarı-köprü dönüştürücü için “Çok hızlı entegre devre Donanım Açıklama Dili-Analog Karma Sinyal” (VHDL-AMS) tabanlı modelleme yöntemi önerilmiştir. Karşılıklı endüktans değerleri, makine rotorunun faz akımı ve açısına göre VHDL-AMS tarafından hesaplanır. Sonuç olarak, makine rotorunun konumuna bağlı olarak değişen endüktans önerilen yöntemle dinamik olarak belirlenir.

**Anahtar Kelimeler:** Anahtarlamalı relüktans makinası, ARM, KKARM, VHDL-AMS

## 1. Introduction

Although first SRM is produced in 1838, it is not widely

used until late 1970s since its control issues. However, SRM has many advantageous in adjustable-speed applications for their simple structure, durability, ability to continue operating as designed despite internal or external changes, high torque capability, workability at high speeds and high temperature by its very nature (Shahabi et al. 2015, Ding et al 2014). SRMs are used in automotive industry, air

\*Corresponding author: [cihan.sahin@bilecik.edu.tr](mailto:cihan.sahin@bilecik.edu.tr)

Cihan Şahin  [orcid.org/0000-0001-6430-7827](https://orcid.org/0000-0001-6430-7827)

Ayşe Ergün Amaç  [orcid.org/0000-0003-3215-0129](https://orcid.org/0000-0003-3215-0129)

Mevlüt Karaçor  [orcid.org/0000-0001-5408-9117](https://orcid.org/0000-0001-5408-9117)

industry, excitation of railway and light-rail system tools, home appliances, industrial drives for general purpose, servo systems, and robotics applications as well as compressor, fan, pump, centrifuge excitation (Fahimi et al. 2007, Desai et al. 2009a, Desai et al. 2009b). Furthermore, SRMs usage has gradually grown up at vehicles that work with alternative energy sources. SRMs have quite simple structure compared to other electrical machines. There is neither winding nor magnet on rotor of SRM [Xu et al. 2012]. The most important reason of many works doing on SRM lately is that its simple structure and low cost. Besides SRMs offer high efficiency and long extended speed at constant power operation (Yadlapalli 1999). SRM has high resistance for overloading electrically but low potential for magnetic loading in contrast to the induction motor. Eliminating heat dissipation in SRM is simple, since its stator and rotor windings cause the losses mostly. Moreover, there is no risk of demagnetization in SRM unlike in permanent magnet motor. Consequently, SRM can be employed in rugged conditions and/or in required ultra-high speed for its simple structure [Cheng et al. 2015]. However, SRMs have disadvantages such as their being switched electronically and not fed by AC or DC sources directly. High torque ripple and acoustic noise due to highly nonlinear magnetic characteristics of salient poles are other drawbacks of these machines (Sahin et al. 2011, Ma et al. 2013). SRM has windings, which cling to stator teeth contour with short pole step (Sahin et al. 2012). Stator-rotor structure of a 6/4 classical SRM is shown in Figure 1.

When the proper phase in SRM is excited, dynamic rotor acts to reduce circuit reluctance. In order to provide continuity at rotor turning, windings of SRM are excited respectively. The winding structure of SRM has evolved with the studies that accomplished by Mecrow to increase of SRM's performance. Mecrow have made simple alterations at the machine windings without additional wrappings (Mecrow 1993). Surprisingly, this simple changing has improved positive torque production of the machine. SRM realized by Mecrow has 20-30% more average torque than classic SRM's torque and called Fully Pitched SRM (FPSRM) or Mutually Coupled SRM (MCSRSM). Stator-rotor structure of a 6/4 MCSRSM is shown in Figure 2.

However, torque is obtained from the mutual couple reluctance instead of the phase reluctance in this configuration. The mutual couple reluctance occurs between phases and changes according to rotor position of the machine. Thus, torque production that depends on the reluctance varies by

air-gap between rotor and stator at SRM. The variation of the reluctance and inductance in SRMs lead to the establishment of flux and therefore rotational motion. Thus, accurate modeling of the SRM's inductance is essential. As a result, a VHDL-AMS based modeling method for an asymmetric H-type half-bridge converter as a MCSRSM drive is proposed in this study.

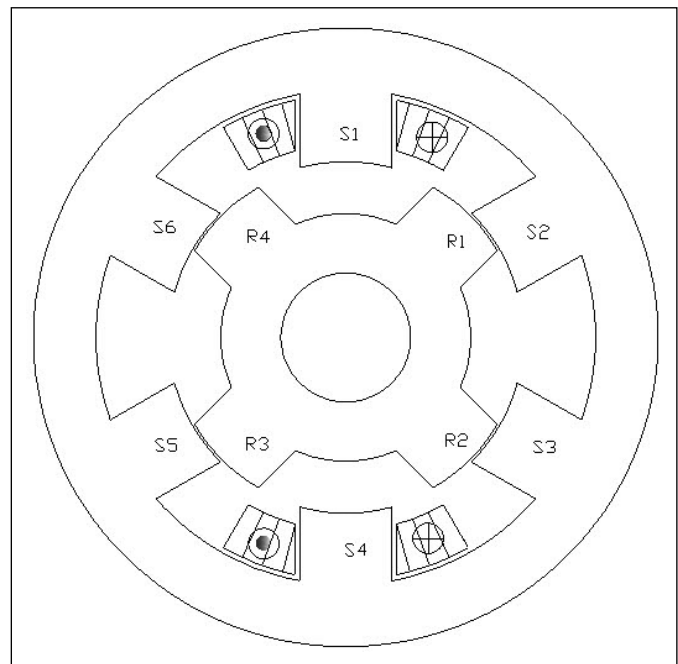

Figure 1. Stator-rotor structure of classic SRM.

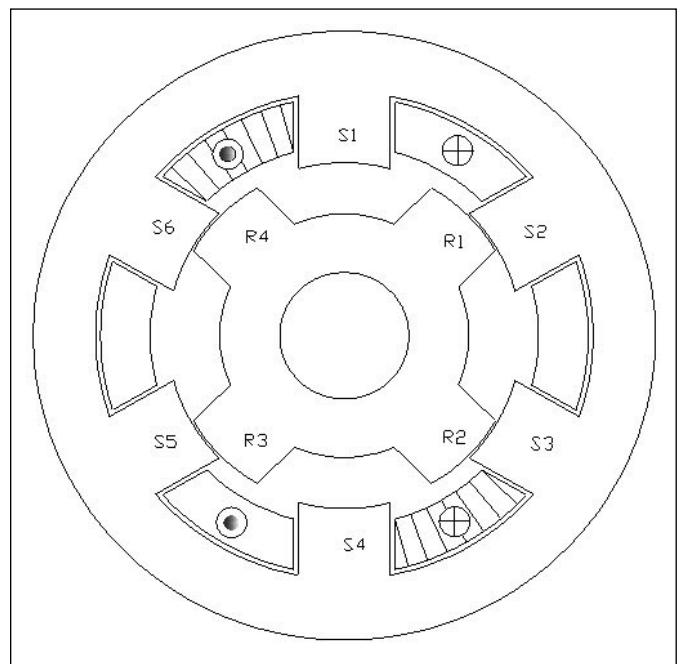

Figure 2. Stator-rotor structure of MCSRSM.

## 2. Materials and Methods

In the study, geometric dimensions of the MCSRSM were determined using Matlab GUI. The drawing of the machine was done in the AutoCAD program. MCSRSM static analysis was also performed at Maxwell. The asymmetric

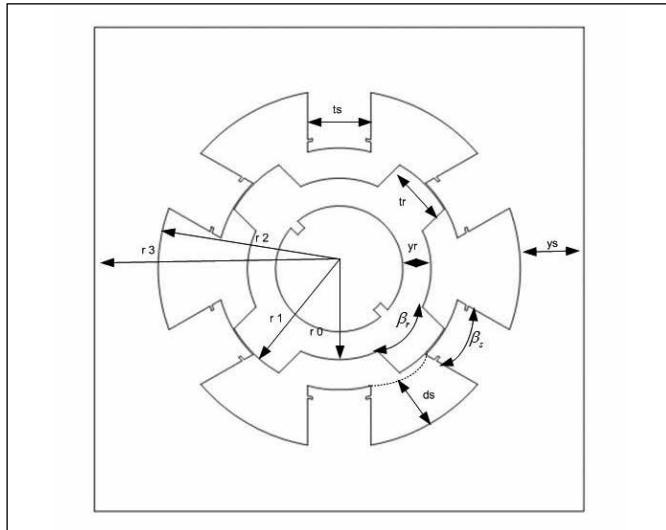

Figure 3. Geometric structure of the proposed MCSRSM.

H-type half-bridge converter model is implemented in the Simplorer package program. For the MCSRSM model to be implemented in the simplorer environment, the inductance calculations in the driver substructure have been performed based on the VHDL-AMS. The inductance value obtained from the VHDL-AMS basis is compared with the value obtained from the static analysis. In this way, The correctness of the MCSRSM model, which will be realized in the Simplorer environment in the future, is supported.

## 3. The Machine Design

A three phase, 100 watts, 6/4 SRM is designed for the analysis. General dimensions of the machine are obtained from “Matlab GUI Based SRM Design Program” (Kuyumcu and Karaçor 2007). Geometric structure of the machine is given in Figure 3. Dimensions of the proposed MCSRSM are presented in Table 1.

## 4. Finite Element Analysis of the Proposed MCSRSM

Figure 4 shows mutual inductance and torque curves of MCSRSM at different currents, which is obtained from Finite Element Method (FEM) analysis.

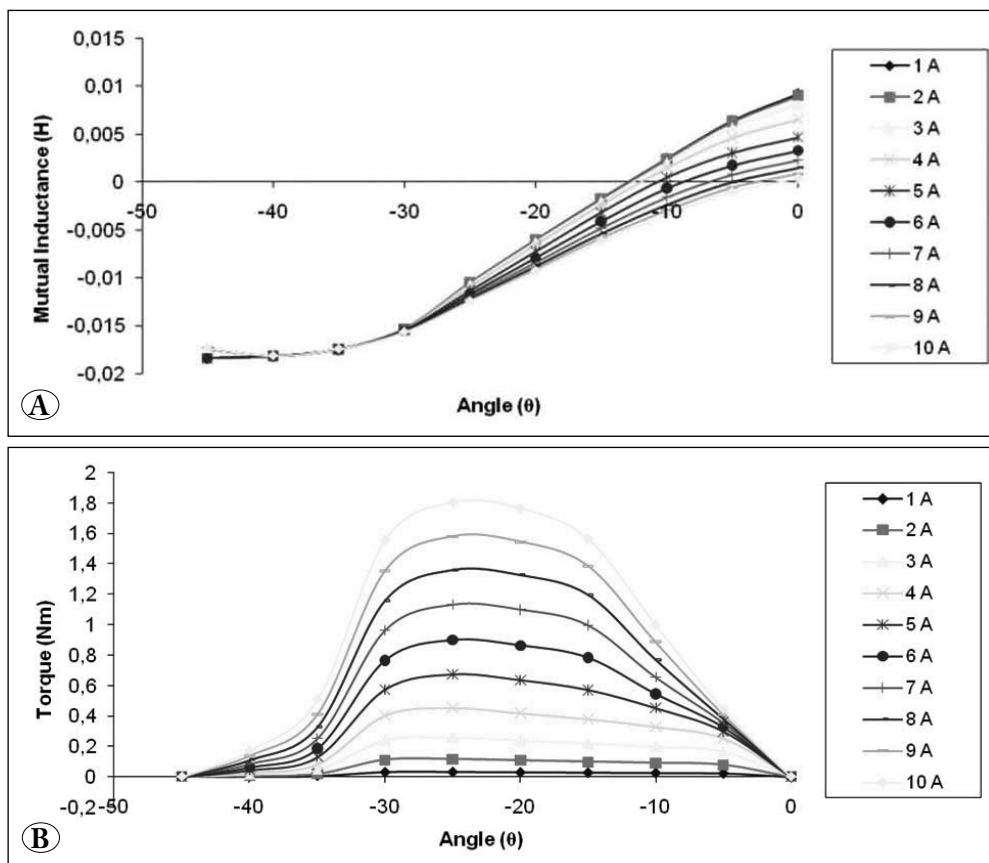

Figure 4. Mutual inductance and torque curves of the proposed MCSRSM. A) Mutual inductance variation of the proposed MCSRSM at different currents. B) Torque variation of the proposed MCSRSM at different currents.

## 5. Results and Discussion

In order to design a VHDL-AMS-based asymmetric H-type half-bridge converter for the proposed MCSRM, FEM analysis of the machine is realized. Mutual inductance values obtained from FEM analysis are transferred to VHDL-AMS context, so the values are linearized. It is ensured that new mutual inductance values calculated by VHDL-AMS to take proper values. Flowchart of the study is shown in Figure 5.

Both switches of the phase winding are in conduction mode at positive voltage loop on asymmetric half-bridge converter as shown in Figure 6. For example, T1 and T2 are ON and the winding current on phase A increases quickly. While T1 is OFF and T2 is ON, the winding current flows through T2 and D2 in zero voltage loop. Both switches are OFF in negative voltage loop, therefore collected energy on the winding is sent back to the source through D1 and D2.

### 5.1. Linearization of Mutual Inductance Values in VHDL-AMS Context

Mutual inductance values obtained from FEM analysis of the machine, are linearized by VHDL-AMS. Therefore, it is produced new output mutual inductance values. The changing of mutual inductance value that is calculated by VHDL-AMS at 10 Amps is shown Figure 7A, B shows the variation of mutual inductance value, which is obtained from FEM analysis of the machine at 10 Amps.

### 5.2. Modeling of the Converter

The proposed VHDL-AMS-based three phase asymmetric H-type half-bridge converter is shown in Figure 8.

Since the torque production of MCSRM depends on mutual inductance that occurs between phases, the phase self-inductances are neglected in the circuit. VHDL-AMS linearization is written separately for three mutual inductances as MAB, MAC, and MBC. The current drawn by each phase and the time-dependent angle are read by VHDL-AMS block and then the block produces new values for MAB, MAC, and MBC. There are two switches to control the phase in the simulation circuit. While one of the switches is in chopper mode, the other one provides hysteresis control in the circuit. MOSFET is preferred as switches, since the proposed SRM is 100 watts.

Because two phases are online at the same time in a VHDL-AMS-based modeled drive, switching and other losses are twice as well as current drawn by the circuits comparing

**Table 1.** Geometric Dimensions of the Proposed MCSRM.

Symbol	Value	Symbol	Value
$r_0$	18.75 mm	$y_s$	13.00 mm
$r_1$	24.5 mm	$y_r$	05.75 mm
$r_2$	37.00 mm	$d'_s$	12.00 mm
$r_3$	50.00 mm	$d'_r$	05.75 mm
$t_s$	13.05 mm	$\beta_r$	30°
$t_r$	13.05 mm	$\beta_s$	30°
$g$	00.50 mm		

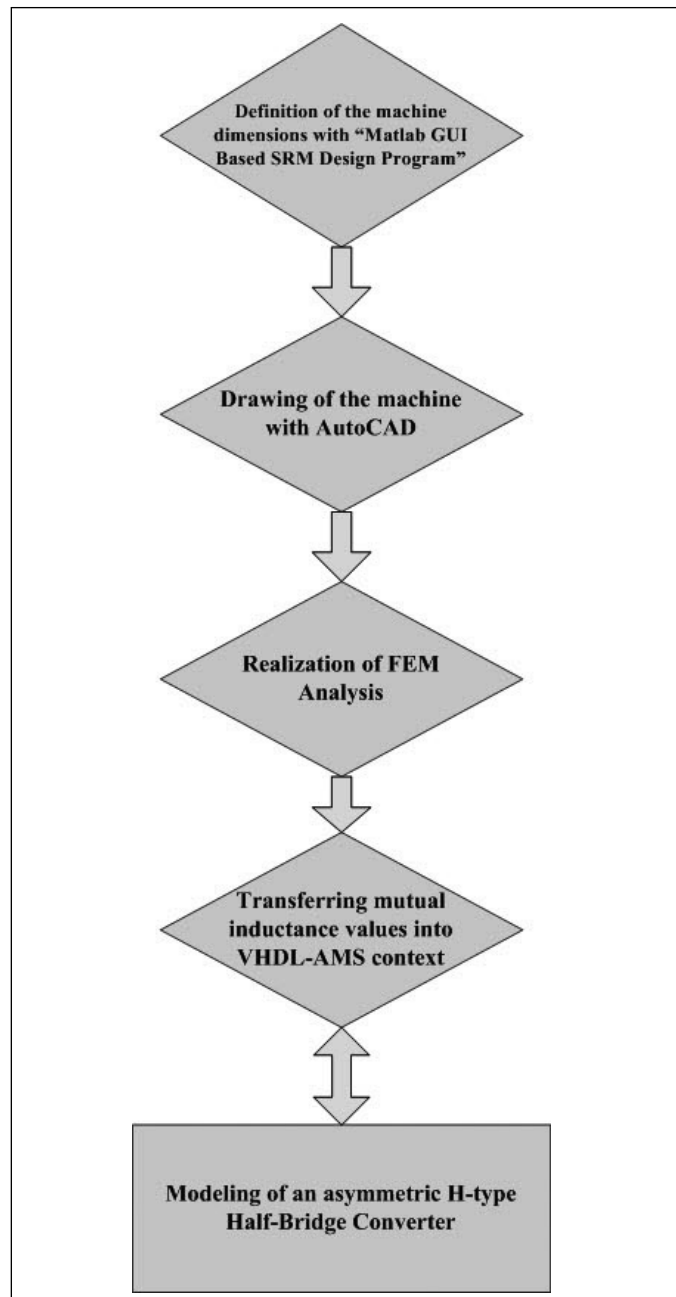

**Figure 5.** Flowchart of the study.

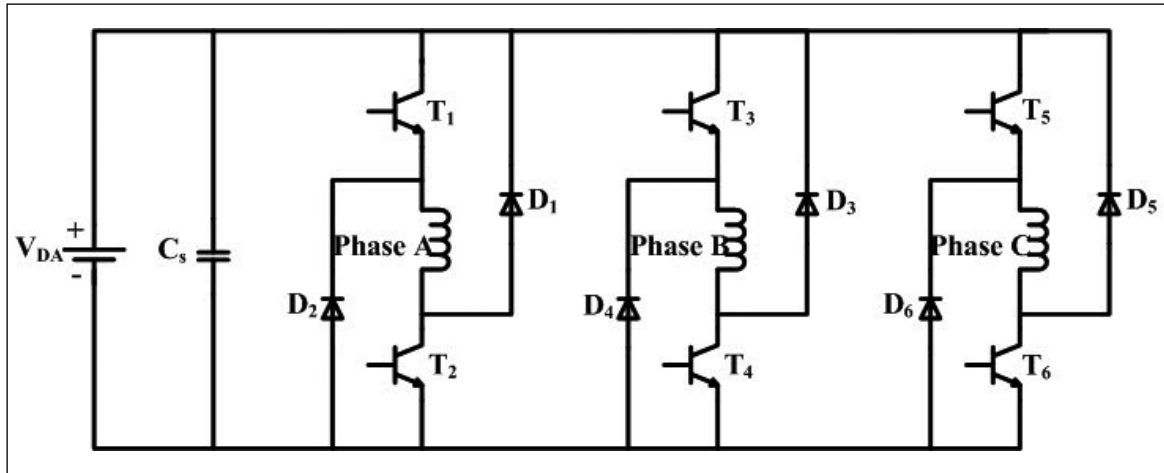

Figure 6. A three phase asymmetric half-bridge converter.

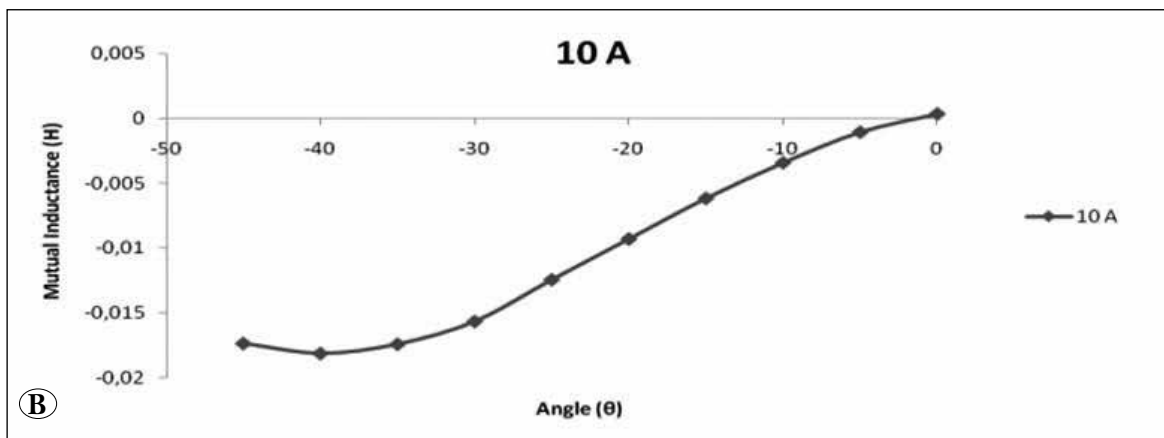
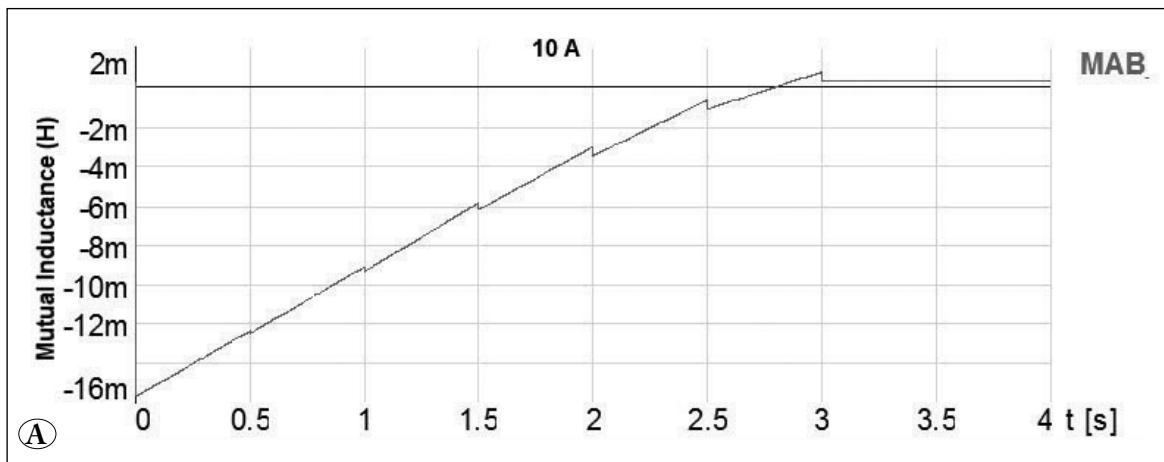

Figure 7. Comparison of the mutual inductances. A) MAB curve, calculated by VHDL-AMS at 10 Amps. B) MAB curve, obtained from FEM analysis at 10 Amps.

to the other models. The curves of current and mutual inductances for the proposed model are shown in Figure 9.

### 6. Conclusion

The inductance values obtained from FEM analysis are used for SRM modeling in general. Determination of

the inductance values accurately is very important for the machine modeling. Correct inductance value is acquired with different method in this study. Thanks to the proposed VHDL-AMS method, new inductance values that depend on continuously changing phase currents and angle are calculated and proper inductance value is assigned to the machine model.

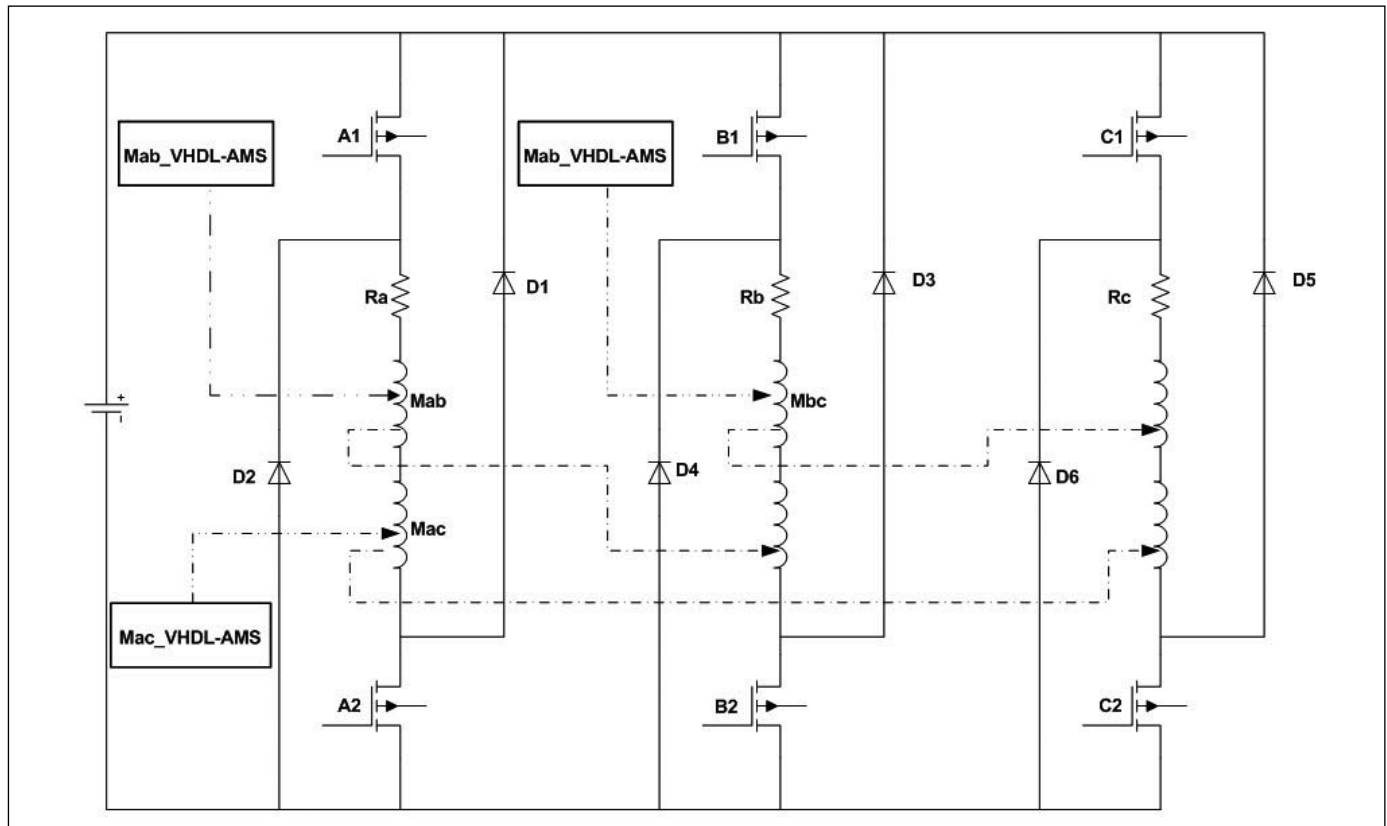

Figure 8. The simulation circuit of a three phase asymmetric H-type half-bridge converter based on VHDL-AMS modeling.

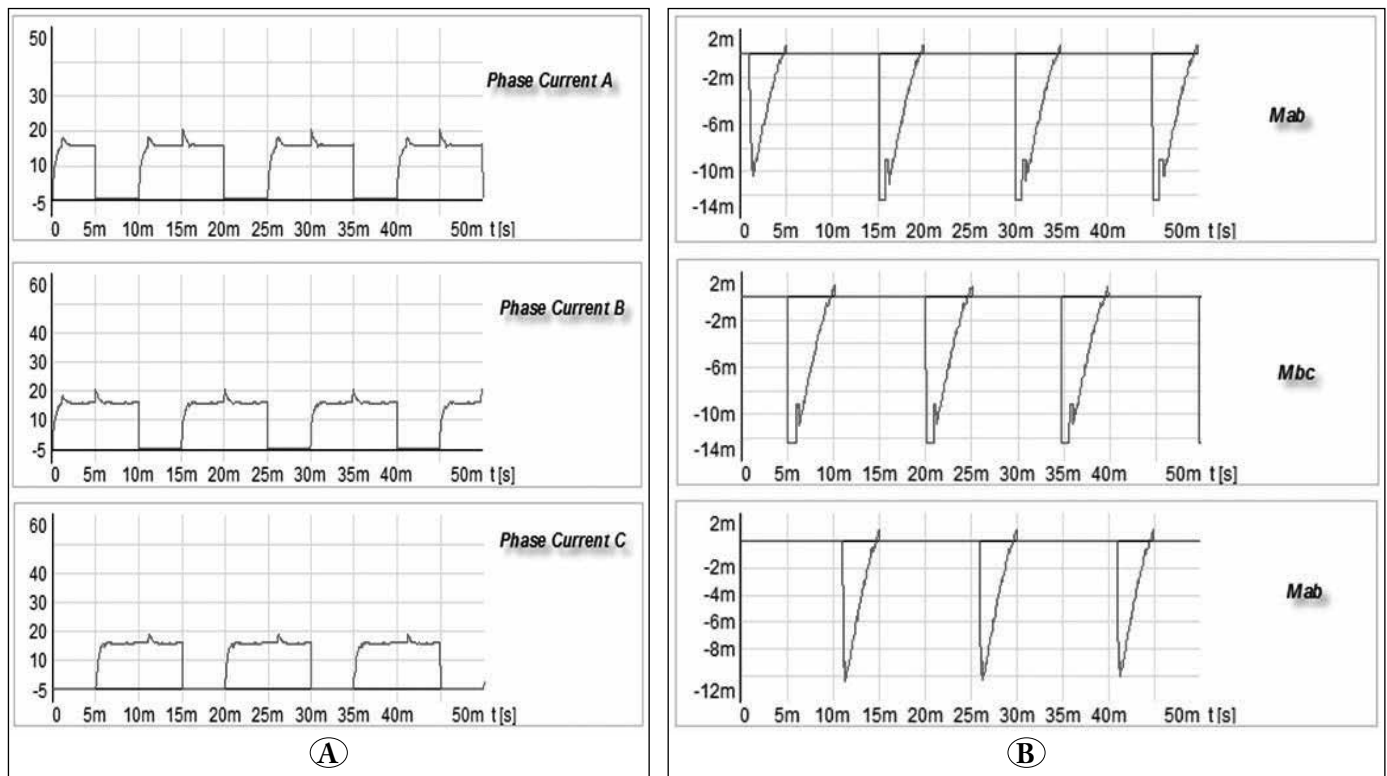

Figure 9. A) Phase currents. B) Mutual Inductances

## 7. References

- Cheng, H., Chen, H., Yang, Z. 2015.** Design indicators and structure optimization of switched reluctance machine for electric vehicles. *IET Electr. Power Appl.*, 9(4): 319–331.
- Desai, PC., Krishnamurthy, M., Schofield, N., Emadi A. 2009a** Design and performance evaluation of a novel 6/10 switched reluctance machine. *IEMDC '09*, Miami, FL, 75-762, USA.
- Desai, PC., Krishnamurthy, M., Schofield, N., Emadi, A. 2009b** Switched reluctance machines with rotor poles higher than stator poles for improved output torque characteristics. *IECON '09*, Porto, 1338-134, Portugal.
- Ding, W., Yin, Z., Liu, L., Lou, J., Hu, Y., Liu, Y. 2014.** Magnetic circuit model and finite element analysis of a modular switched reluctance machine with E-core stators and multi-layer common rotors. *IET Electr. Power Appl.*, 8(8):296-309.
- Fahimi, B., Emadi, A., Sepe, BR. 2007** A switched reluctance machine based starter/alternator for more electric cars. *IEEE T Energy Conver.* 19 (1), 116–124.
- Kuyumcu, FE., Karacor, M. 2007.** Matlab GUI Based SRM Design Program. *ACEMP '07*, Bodrum, 846-848, Turkey.
- Ma, C., Qu, L., Tang, Z. 2013.** Torque ripple reduction for mutually coupled switched reluctance motor by bipolar excitations. *IEMDC*, Chicago, IL, 1211-1217, USA.
- Mecrow, BG. 1993.** Fully pitched-winding switched-reluctance and stepping-motor arrangements, *IEE Proc. B*, 140(1), 61–70.
- Sahin, C., Amac, AE., Karacor, M., Emadi, A. 2011.** A comparative analysis of the effects of rotor molding clinches on torque ripple of mutually coupled SRMs. *I.R.E.E.*, 6(4): 1627-1635.
- Sahin, C., Amac, A.E., Karacor, M., Emadi, A. 2012.** Reducing torque ripple of switched reluctance machines by relocation of rotor moulding clinches. *IET Electr. Power Appl.*, 6(9):753-760.
- Shahabi, A., Rashidi, A., Afshoon, M., Nejad, SMS. 2015.** Commutation angles adjustment in SRM drives to reduce torque ripple below the motor base speed. *Turk. J. Elec. Eng. Comp. Sci.*, 1-14.
- Xu, YZ., Zhong, R., Chen, L., Lu, SL. 2012.** Analytical method to optimize turn-on angle and turnoff angle for switched reluctance motor drives. *IET Electr. Power Appl.*, 6(9): 593–603.
- Yadlapalli, N. 1999.** Implementation of A Novel Soft Switching Inverter for Switched Reluctance Motor Drivers. *Master Thesis*, Virginia Polytechnic Institute and State University, 1s.